

1PH SERIES

LOW NOISE
HYDRAULIC HELICAL GEAR PUMPS

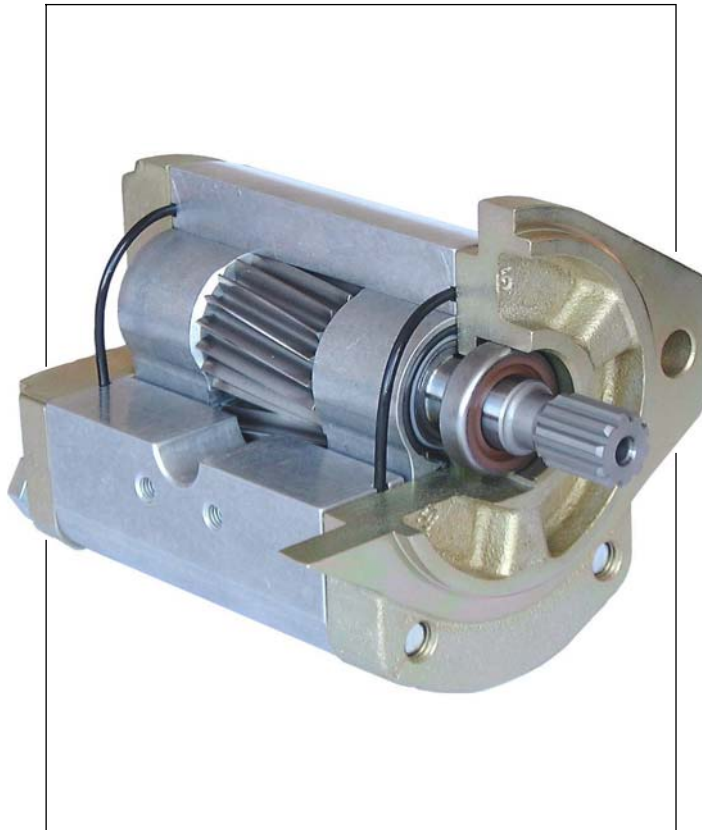

6 to 28.1 cm³/rev (0.366 to 1.715 in³/rev)
280 bar (4060 psi) peak pressure

1PH SERIES TECHNICAL DATA

OPERATING PARAMETERS

1PH Series pumps are designed to provide high performance levels and long life when operated within the parameters shown. For operation outside these parameters please consult your David Brown Hydraulics representative.

Maximum port pressures	see below.	
Speed Range	All models	see table below
Temperature	Minimum at start-up	-40°C (-40°F)
	Maximum continuous	+80°C (+176°F)
	Maximum intermittent	+100°C (+212°F)
Viscosity	Maximum at start-up	2000 mm ² /sec
	Maximum continuous	250 mm ² /sec
	Minimum continuous	10 mm ² /sec
	Optimum	15-25 mm ² /sec
Fluid Cleanliness	To ISO4406 solid contaminant	
	Start-up period	21/17
	Maximum in service	19/15
	Optimum	16/11
	Maximum water	0.1%
Fluid Velocity	Maximum in INLET line	2.5 m/sec (8 ft/sec)
	Recommended in INLET line	1.5 m/sec (5 ft/sec)
Fluids	All data is quoted for mineral oils HM and HV.	
	For fire resistant and environmentally aware fluids please contact your David Brown representative.	
Rotation	Clockwise or Anti-clockwise viewed from shaft end (not reversible).	

MODEL	DISPLACEMENT cm ³ /rev (in ³ /rev)	OUTLET PRESSURE		SPEED	
		Rated - bar (psi)	Peak - bar (psi)	Minimum	Maximum
1PH 060	6.0 (0.366)	250 (3625)	280 (4060)	600	3000
1PH 082	8.2 (0.500)	250 (3625)	280 (4060)	600	3000
1PH 095	9.5 (0.580)	250 (3625)	280 (4060)	600	3000
1PH 119	11.9 (0.726)	250 (3625)	280 (4060)	600	3000
1PH 140	14.0 (0.854)	250 (3625)	280 (4060)	600	3000
1PH 168	16.8 (1.025)	250 (3625)	280 (4060)	600	3000
1PH 190	19.0 (1.159)	250 (3625)	280 (4060)	600	3000
1PH 229	22.9 (1.397)	210 (3045)	250 (3625)	600	2500
1PH 281	28.1 (1.714)	170 (2465)	210 (3045)	600	2500

INLET CONDITIONS

It is essential that pumps are installed so that the pump can draw sufficient oil under all operating conditions. 1PH Series pump inlet porting is designed to facilitate full volume fill but the following machine design recommendations should be followed.

- Never run pumps dry - particular care should be taken to open any shut-off valves.
- Use large diameter pipes and fittings and avoid sharp bends and long lengths.

Fluid velocity should not exceed 2.5 m/sec (8.0 ft/sec) calculated by:

$$V = \frac{21.22Q}{D^2} \text{ m/sec where } \begin{array}{l} V = \text{velocity (m/sec)} \\ Q = \text{flow rate (l/min)} \\ D = \text{bore diameter (mm)} \end{array}$$

$$V = \frac{0.408Q}{D^2} \text{ ft/sec where } \begin{array}{l} V = \text{velocity (ft/sec)} \\ Q = \text{flow rate (US gal/min)} \\ D = \text{bore diameter (inches)} \end{array}$$

- If possible mount the pump below the lowest level of fluid in the tank. If necessary prime the pump on start-up.
- Ensure that inlet lines are airtight.
- Particular care should be taken where high speeds and/or high fluid viscosities are involved.

As a general rule pressure at the pump inlet should not be less than 0.93 bar absolute (2" Hg depression) at normal viscosity of 23 mm²/sec (110 SSU).

1PH SERIES INTRODUCTION

SUPER QUIET, HIGH PERFORMANCE HYDRAULIC PUMPS

1PH pumps incorporate unique David Brown Hydraulics helical gear technology to give highest performance with lowest noise levels within an aluminium body.

Helical gears reduce pressure ripple by smoothing out small flow variations associated with gear pump technology and significantly reduces generated noise within the machine structure. Using appropriate shafts, bearings, and cast iron end plates within a rigid construction gives good life expectancy.

Component accuracy and pressure compensated side plates ensure that high performance is maintained.

A RANGE OF SINGLE AND MULTIPLE PUMPS

Pump elements are available with displacements from 6.0 to 22.9 cm³/rev (0.366 to 1.397 in³/rev) for maximum continuous operating pressures of 250 bar and peak operating pressures of 280 bar. Maximum inlet pressure is 2 bar.

Pumps can be supplied as single, or double units. Triple, quadruple and add-on units to other pumps are available in a wide variety of combinations.

Please contact your David Brown Hydraulics representative for more information on possible combinations of triple and quadruple pumps.

SINGLE PUMPS

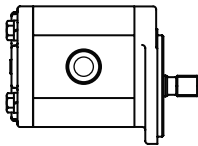

DOUBLE PUMPS

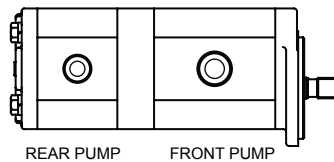

ADD ON TO OTHER PUMPS

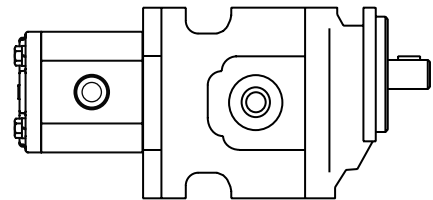

Triple, quad and other combinations are also available, please consult your DB Hydraulics representative for details

1PH SERIES MODEL NUMBERS

1 P H 1 4 0 A G T 5 D C S S

Series

Displacements

SINGLE PUMPS

Code	DISPLACEMENT	
	cm ³ /rev	in ³ /rev
060	6.0	0.366
082	8.2	0.500
095	9.5	0.580
119	11.9	0.726
140	14.0	0.854
168	16.8	1.025
190	19.0	1.159
229	22.9	1.397
281	28.1	1.715

Rotation

Code	Rotation
A	Anti-clockwise
C	Clockwise

viewed from shaft end

Mounting Flange type

Refer to page 4 for details

Drive Shaft type

Refer to page 5 for details

repeat for each pumping section

repeat for each pumping section

repeat for each pumping section

Outrigger bearing

Code	Description
O	Required
S	Not required

Refer to page 6 for details

Rear cover

Code	Description
S	Standard
R	Ports in rear cover
L	With load sensing valve
V	With relief valve
Y	With priority flow valve
Z	With flow control valve

Refer to your local David Brown Hydraulics representative for details of availability of codes L, Y & Z

Outlet port type

Refer to page 6 for options

Inlet port type

Refer to page 6 for options (Use code 00 for No Port - applies to sections of multiple pumps only)

1PH SERIES TECHNICAL DETAILS

MOUNTING FLANGES

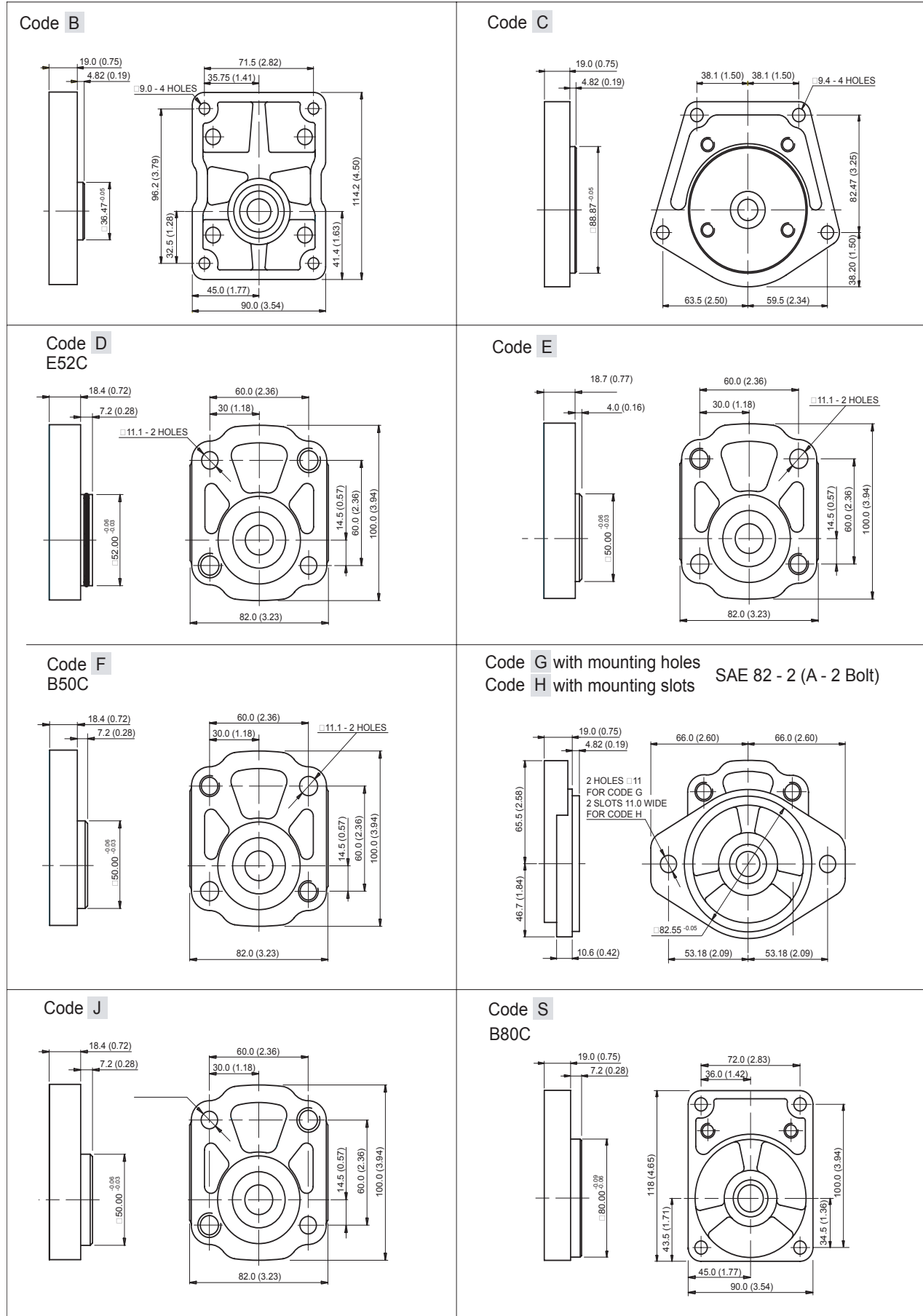

1PH SERIES TECHNICAL DETAILS

DRIVE SHAFTS

<p>Shaft Type T5</p> <p>40.5 (1.59) 27.5 (1.08) 10.5 (0.41) 9.4 (0.37) 3.0 $^{-0.030}$ (0.118 $^{-0.001}$) 16.0 (0.63) 6.5 (0.26) 50 Nm Basic taper 1:5 Ref.diameter 17.0 M12x1.5</p>	<p>Shaft Type T8</p> <p>40.0 (1.57) 28.0 (1.10) 12.1 (0.48) 9.4 (0.37) 3.2 $^{-0.020}$ (0.126 $^{-0.001}$) 16.0 (0.63) 6.3 (0.25) 50 Nm Basic taper 1:8 Ref.diameter 17.0 M12x1.5</p>
<p>Shaft Type P1</p> <p>44.70 (1.760) 32.5 (1.279) 8.1 (0.32) 19.0 (0.75) 4.8 $^{-0.03}$ (0.189 $^{-0.001}$) 19.56 (0.770) 17.46 (0.687) 7/16" - 20 UNF</p>	<p>Shaft Type P2</p> <p>24.3 (0.96) 15.87 (0.625) 17.6 (0.69) 32.0 (1.26) KEY - 3.97 x 3.97 M6 x 1 x 12 (0.47) DEEP</p>
<p>Shaft Type R1</p> <p>6.5 $^{+0.1}$ (0.256 $^{+0.004}$) 2.7 $^{+0.5}$ (0.11 $^{+0.02}$) 8.0 $^{-0.083}$ (0.315 $^{-0.001}$) 17.4 (0.688) 12.0 $^{-0.2}$ (0.47 $^{-0.008}$) 32.0 (1.26) 30.0 (1.18)</p>	<p>Shaft Type S1</p> <p>31.5 (1.24) 8.5 (0.33) KEY - 3.97 x 3.97</p> <p>Involute Spline 9 Teeth 16/32 DP 16-4/SAE'A' (SAE J744)</p>
<p>Shaft Type S2</p> <p>13.8 (0.54) 7.8 (0.31) 32.5 (1.28)</p> <p>SAE Spline Flat Root Side Fit 11 Teeth 16/32 DP 19-4 (SAE J744)</p>	<p>Shaft Type S3</p> <p>3.8 (0.15) 10.0 (0.39)</p> <p>8 Teeth DIN 5482 Spline B15X12</p>

Please note: Other shafts may be available which are not displayed here. Please contact your local representative.

1PH SERIES TECHNICAL DETAILS

PORT TYPES

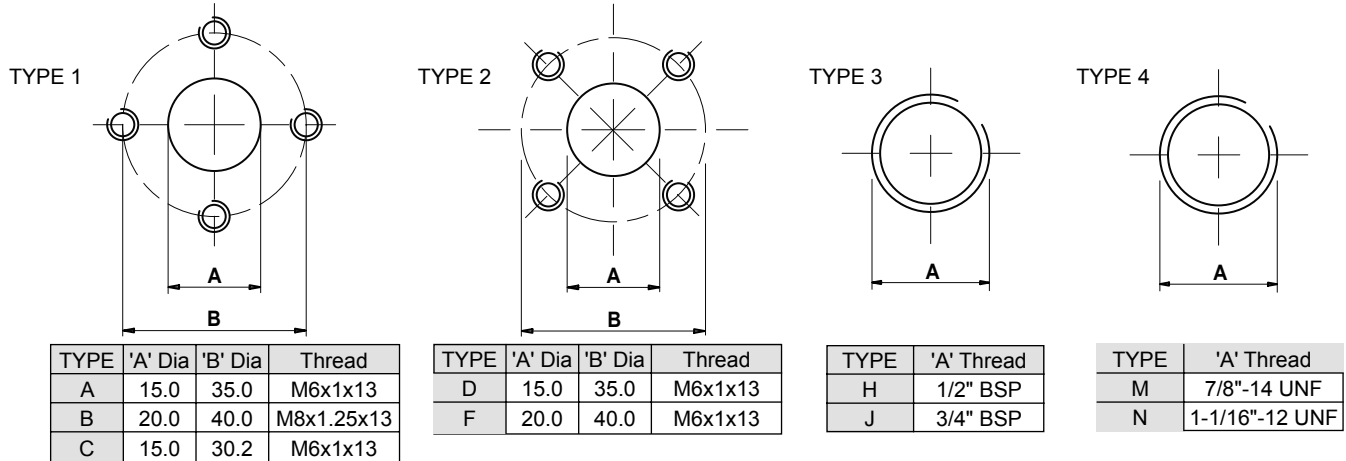

PORT TYPE	Flange Ports - Type 1			Flange Ports - Type 2			Threaded Ports - Type 3			Threaded Ports - Type 4		
	INLET	INLET	OUTLET	INLET	INLET	OUTLET	INLET	INLET	OUTLET	INLET	INLET	OUTLET
	A	B	C	D	F	D	H	J	H	M	N	M
MODEL TYPE	060	■		■		■	■		■	■		■
	082	■		■		■	■		■	■		■
	095	■		■		■	■		■	■		■
	119		■	■		■		■	■		■	■
	140		■	■		■		■	■		■	■
	168		■	■		■		■	■		■	■
	190		■	■		■		■	■		■	■
	229		■	■		■		■	■		■	■

■ = Preferred option. Other port types may be available - consult your David Brown Hydraulics representative for further information

OUTRIGGER BEARINGS

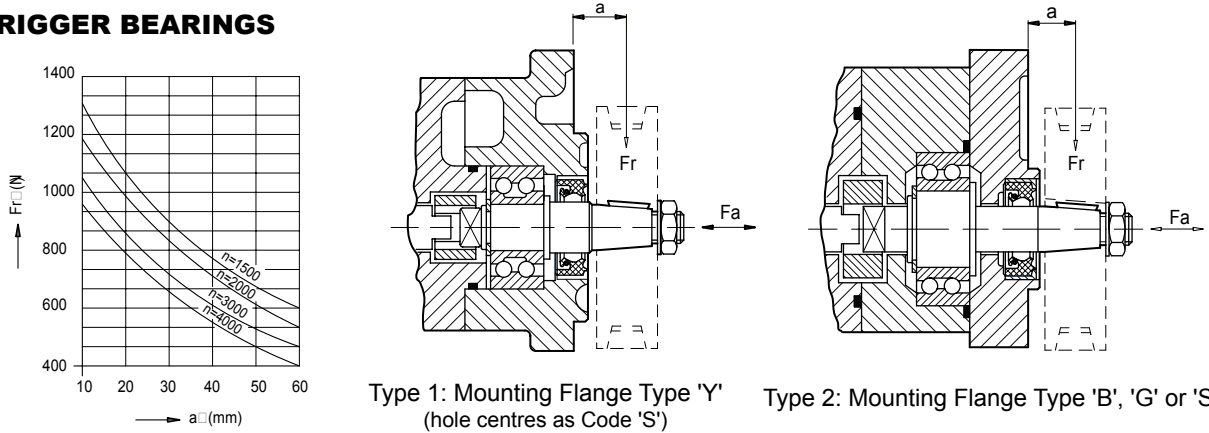

EFFICIENCY AND NOISE

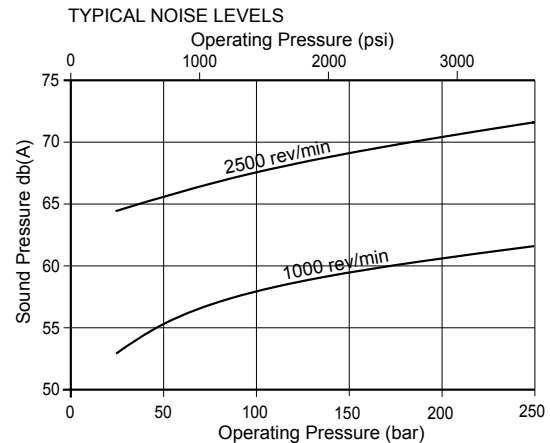
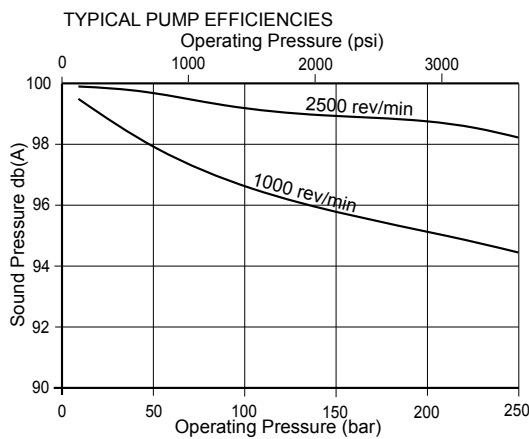

1PH SERIES INSTALLATION DATA

NOTE:
Width across port
faces = 84 (3.307)

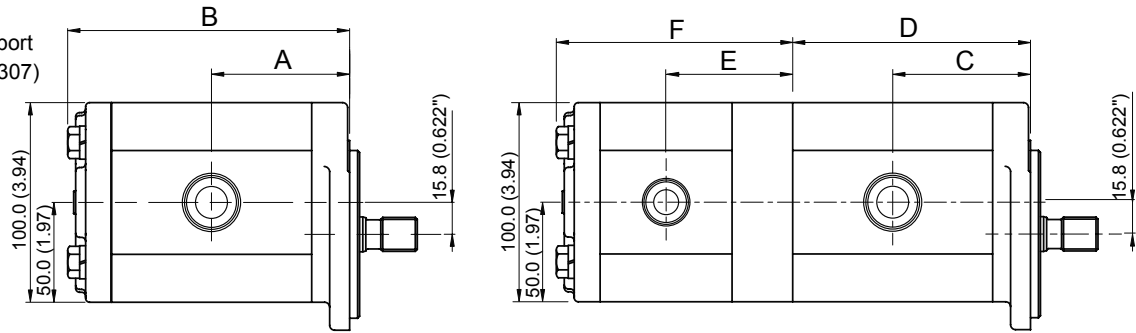

NOTE: Dimensions shown are for an SAE 82-2 (A-2Bolt) Flange. Please make an allowance when using other flange types.

PUMP MODEL	SINGLE PUMPS		DOUBLE PUMPS			
	A	B	C	D	E	F
060	40.4 (1.590)	83.8 (3.299)	40.4 (1.590)	61.8 (2.434)	51.9 (2.043)	95.3 (3.752)
082	42.7 (1.681)	88.5 (3.484)	42.7 (1.681)	66.5 (2.618)	54.2 (2.134)	100.0 (3.937)
095	52.1 (2.051)	107.3 (4.224)	52.1 (2.051)	85.3 (3.357)	63.6 (2.504)	118.7 (4.673)
119	54.7 (2.153)	112.4 (4.425)	54.7 (2.153)	90.4 (3.557)	66.1 (2.602)	123.8 (4.874)
140	63.9 (2.516)	130.8 (5.150)	63.9 (2.516)	108.8 (4.284)	75.4 (2.969)	142.3 (5.602)
168	66.9 (2.634)	136.8 (5.386)	66.9 (2.634)	114.8 (4.518)	78.3 (3.083)	148.2 (5.835)
190	69.2 (2.724)	141.4 (5.567)	69.2 (2.724)	119.4 (4.702)	80.7 (3.177)	152.9 (6.020)
229	72.4 (2.890)	149.7 (5.894)	72.4 (2.890)	127.7 (5.028)	84.8 (3.339)	161.2 (6.346)
281	78.1 (3.075)	160.7 (6.328)	78.1 (3.075)	138.7 (5.462)	89.6 (3.527)	172.2 (6.781)

Please note: The lengths in this table are true for flange types B, C, G, H, & S. For flange types D, E, F, & J. Please refer to page 4 of this catalogue for flange length variation.

1PH SERIES SERVICING DATA

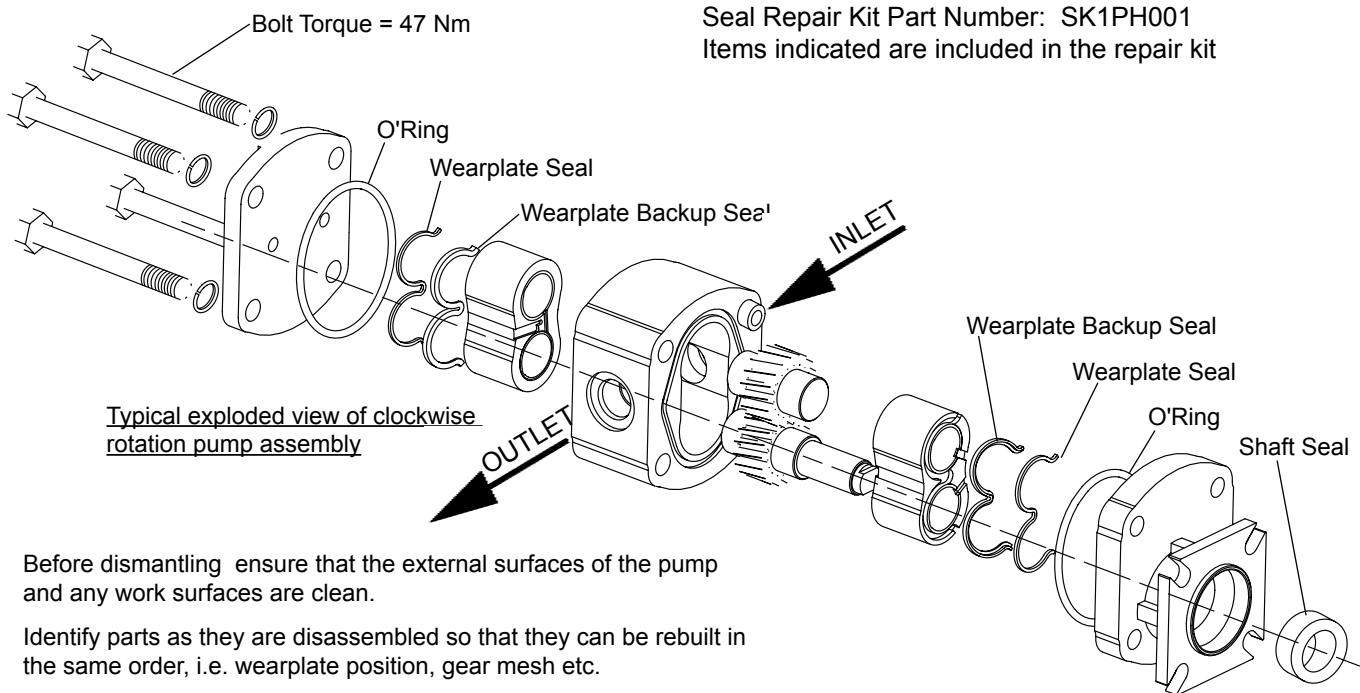

Before dismantling ensure that the external surfaces of the pump and any work surfaces are clean.

Identify parts as they are disassembled so that they can be rebuilt in the same order, i.e. wearplate position, gear mesh etc.

Examine metal parts for signs of degradation or wear, if there are any serious signs of wear on the gears, in the housing, or in the bearings, then the complete pump should be replaced.

If all metal parts are in good order the pump may be rebuilt using new seals throughout.